



DEPARTMENT OF REGULATORY AND ECONOMIC RESOURCES (RER)
BOARD AND CODE ADMINISTRATION DIVISION

MIAMI-DADE COUNTY
PRODUCT CONTROL SECTION
11805 SW 26 Street, Room 208
Miami, Florida 33175-2474
T (786) 315-2590 F (786) 315-2599

www.miamidade.gov/economy

NOTICE OF ACCEPTANCE (NOA)

Layze Systems
3520 NW 51st Street
Miami, FL 33142

SCOPE:

This NOA is being issued under the applicable rules and regulations governing the use of construction materials. The documentation submitted has been reviewed and accepted by Miami-Dade County RER- Product Control Section to be used in Miami Dade County and other areas where allowed by the Authority Having Jurisdiction (AHJ).

This NOA shall not be valid after the expiration date stated below. The Miami-Dade County Product Control Section (In Miami Dade County) and/or the AHJ (in areas other than Miami Dade County) reserve the right to have this product or material tested for quality assurance purposes. If this product or material fails to perform in the accepted manner, the manufacturer will incur the expense of such testing and the AHJ may immediately revoke, modify, or suspend the use of such product or material within their jurisdiction. RER reserves the right to revoke this acceptance if it is determined by Miami-Dade County Product Control Section that this product or material fails to meet the requirements of the applicable building code.

This product is approved as described herein and has been designed to comply with the High Velocity Hurricane Zone of the Florida Building Code.

DESCRIPTION: Aluminum Picket Railing R04

APPROVAL DOCUMENT: Drawing No. 14-445, titled " Aluminum Picket Railing R04 ", sheets 1 through 8 of 8, prepared by Eastern Engineering Group, dated June 08, 2022, signed and sealed by Gonzalo A. Paz, P.E., on June 08, 2022, bearing the Miami-Dade County Product Control Revision stamp with the Notice of Acceptance number and the expiration date by the Miami-Dade County Product Control Section.

MISSILE IMPACT RATING: None

LABELING: Each unit shall bear a permanent label with the manufacturer's name or logo, city, state and the following statement: "Miami-Dade County Product Control Approved", unless otherwise noted herein.

RENEWAL of this NOA shall be considered after a renewal application has been filed and there has been no change in the applicable building code negatively affecting the performance of this product.

TERMINATION of this NOA will occur after the expiration date or if there has been a revision or change in the materials, use, and/or manufacture of the product or process. Misuse of this NOA as an endorsement of any product, for sales, advertising or any other purposes shall automatically terminate this NOA. Failure to comply with any section of this NOA shall be cause for termination and removal of NOA.

ADVERTISEMENT: The NOA number preceded by the words Miami-Dade County, Florida, and followed by the expiration date may be displayed in advertising literature. If any portion of the NOA is displayed, then it shall be done in its entirety.

INSPECTION: A copy of this entire NOA shall be provided to the user by the manufacturer or its distributors and shall be available for inspection at the job site at the request of the Building Official. The structural adequacy of the supporting structures is not part of this approval & shall be reviewed by the corresponding Building Dept.

This NOA revises and renews NOA #15-0310.03 and consists of this page 1, evidence submitted page E-1 as well as approval document mentioned above.

The submitted documentation was reviewed by **Helmy A. Makar, P.E., M.S.**



Helmy A. Makar
07/28/2022

NOA No. 21-1209.03
Expiration Date: 10/26/2027
Approval Date: 07/28/2022

Layze Systems

NOTICE OF ACCEPTANCE: EVIDENCE SUBMITTED

- 1. EVIDENCE SUBMITTED UNDER PREVIOUS APPROVAL #15-0310.03**
 - A. DRAWINGS**
 1. *Drawing No. 14-445, titled " Aluminum Picket Railing R01 ", sheets 1 through 8 of 8, prepared by Eastern Engineering Group, dated October 20, 2017, signed and sealed by Gonzalo A. Paz, P.E., on October 20, 2017.*
 - B. TESTS**
 1. *None.*
 - C. CALCULATIONS**
 1. *Calculations titled " Picket Railing ", pages 1 through 73 of 73, prepared by Eastern Engineering Group, dated October 20, 2017, signed and sealed by Gonzalo A. Paz, P.E., on October 20, 2017.*
 - D. QUALITY ASSURANCE**
 1. *By Miami-Dade County Department of Regulatory and Economic Resources.*
 - E. MATERIAL CERTIFICATIONS**
 1. *None.*
- 2. NEW EVIDENCE SUBMITTED**
 - A. DRAWINGS**
 1. *Drawing No. 14-445, titled " Aluminum Picket Railing R04 ", sheets 1 through 8 of 8, prepared by Eastern Engineering Group, dated June 08, 2022, signed and sealed by Gonzalo A. Paz, P.E., on June 08, 2022.*
 - B. TESTS**
 1. *None.*
 - C. CALCULATIONS**
 1. *None.*
 - D. QUALITY ASSURANCE**
 1. *By Miami-Dade County Department of Regulatory and Economic Resources.*
 - E. MATERIAL CERTIFICATIONS**
 1. *None.*

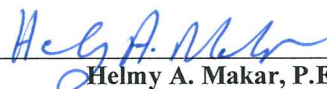

Helmy A. Makar, P.E., M.S.
Product Control Section Supervisor
NOA No. 21-1209.03
Expiration Date: 10/26/2027
Approval Date: 07/28/2022

APPROVED RAILING CONFIGURATIONS

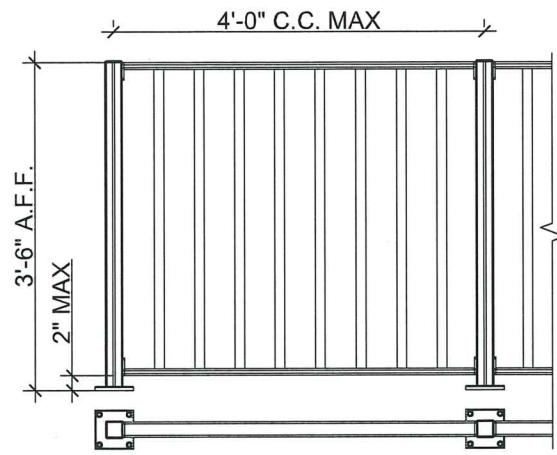

CLASSICAL BALCONY

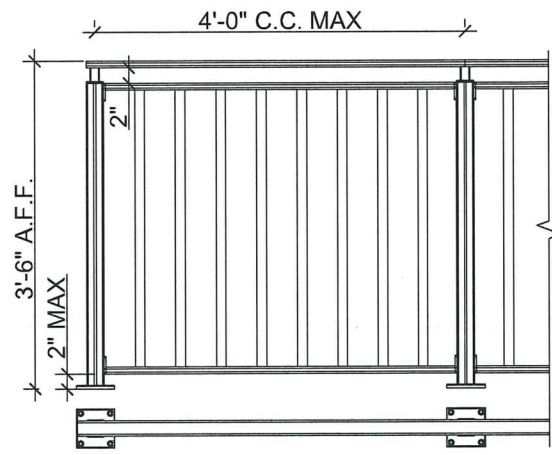

BALCONY W/ TOP RAIL

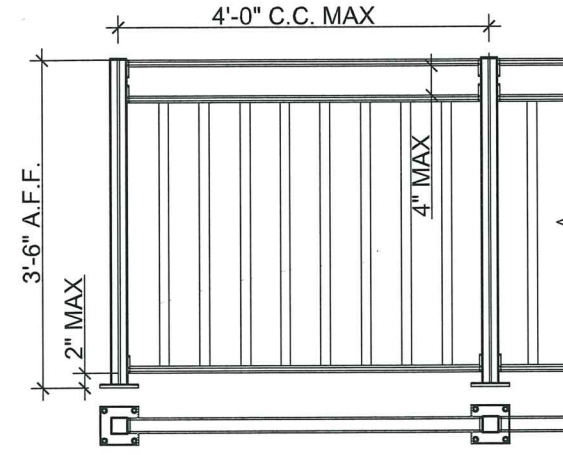

BALCONY W/ DOUBLE CHANNEL

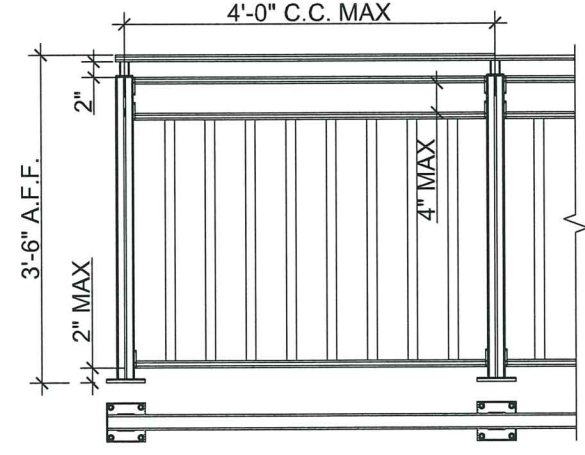

BALCONY W/ DOUBLE CHANNEL & TOP RAIL

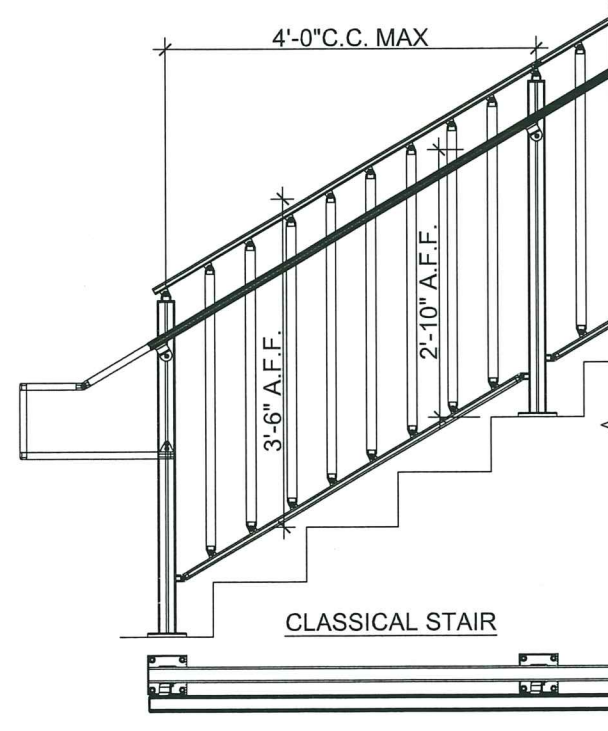

CLASSICAL STAIR

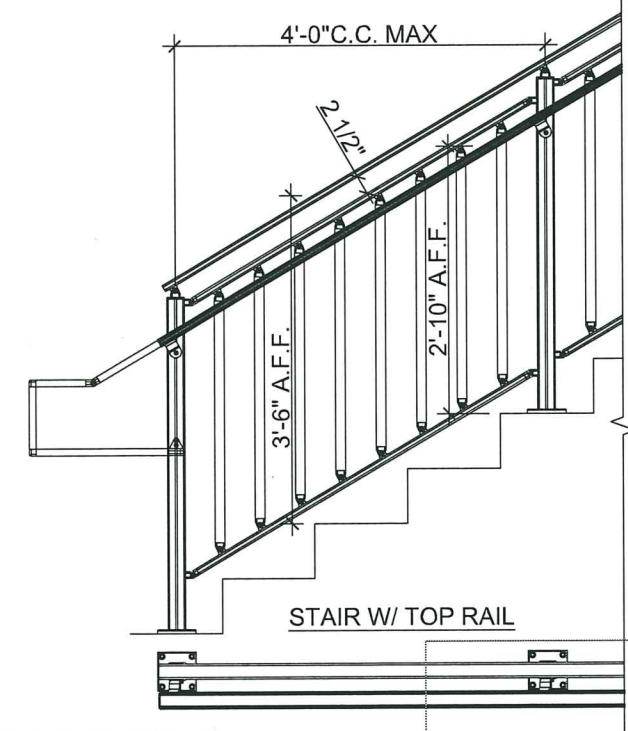

STAIR W/ TOP RAIL

GENERAL NOTES

1. THIS GUARDRAIL ASSEMBLY IS IN COMPLIANCE WITH THE 2014, 2017 & 2020 FLORIDA BUILDING CODE SECTION 1607.8. ACCORDINGLY IT WILL RESIST A LOAD OF MIN 50 LB/FT APPLIED IN ANY DIRECTION AT THE TOP RAIL, IT WILL RESIST A SINGLE CONCENTRATED LOAD OF 200 LBS APPLIED IN ANY DIRECTION AT ANY POINT ALONG THE TOP, AND THE INTERNAL PICKETS WILL WITHSTAND A HORIZONTALLY APPLIED NORMAL LOAD OF 50 LBS APPLIED OVER 1 SQUARE FOOT.
2. THIS PRODUCT HAS BEEN DESIGNED TO COMPLY WITH THE REQUIREMENTS OF THE F.B.C FOR HIGH VELOCITY HURRICANE ZONE (HVHZ).
3. DESIGN CRITERIA FOR ALUMINUM MINIMUM MECHANICAL PROPERTIES AND SAFETY FACTORS ARE IN ACCORDANCE WITH THE ALUMINUM CONSTRUCTION MANUAL LATEST EDITION.
4. ALL ALUMINUM TO BE OF ALLOYS AS SHOWN.
5. CONCRETE SHALL DEVELOP A MINIMUM COMPRESSIVE STRENGTH OF 3000 PSI IN 28 DAYS.
6. THE ABILITY OF THE EXISTING HOST STRUCTURE TO SAFELY SUPPORT THE RAILING SYSTEM IMPOSED LOADS SHALL DETERMINED BY A DESIGN PROFESSIONAL.
7. NO WIND LOAD INCREASE WAS USED IN THE RAILING DESIGN.
8. ANCHORING OR LOADING CONDITIONS OTHER THAN THOSE SHOWN IN THESE DETAILS ARE NOT PART OF THIS APPROVAL.
9. PAINT ALUMINUM AND STEEL HOT GALVANIZED SURFACES IN CONTACT WITH CONCRETE WITH ALKALI-RESISTANT COATINGS, SUCH AS HEAVY-BODIED BITUMINOUS PAINT OR WATER-WHITE METHACRYLATE LACQUER.
10. MECHANICAL FASTENERS TO BE TYPE 304, 316 OR 410 STAINLESS STEEL UNLESS OTHERWISE NOTED.
11. DELIVER AND STORE RAILING IN A DRY AND SAFE LOCATION PROVIDED BY THE GENERAL CONTRACTOR OR OWNER, HANDLE WITH EXTREME CARE TO AVOID MARRING THE FINISHED PRODUCT.
12. BALCONY RAILINGS SHOULD BE INSTALLED FROM THE TOP FLOOR DOWN AND ONLY WHEN ALL PAINTING AND MASONRY WORK IS COMPLETED.
13. WHERE POST INSTALLATION REQUIRES CORE/HAMMER DRILL, SECURED WITH A NON SHRINK, NON METALLIC, STRUCTURAL GROUT MIXED AND PLACE TO COMPLY WITH ANCHORING MATERIAL MANUFACTURERS DIRECTIONS. SEE SHEET S-5 FOR CORE DRILL SPECS.
14. IT SHOULD BE NOTED THAT ALTHOUGH ALL FIELD SPLICES WILL BE DONE IN A WORKMAN LIKE MANNER THESE JOINTS WILL BE VISIBLE UPON COMPLETION AND WILL REQUIRED A MIN GAP OF 1/8 PER TWENTY FOOT SECTION OF TOP OR BOTTOM RAIL, TO ALLOW FOR EXPANSION AND CONTRACTION OF RAILINGS AND OR STRUCTURE.
15. PAINTED ALUMINUM SURFACES SHALL BE CLEANED WITH PLAIN WATER CONTAINING A MILD SOAP OR DETERGENT . NO ABRASIVE AGENTS OR HARSH CHEMICAL ARE TO BE USED (NOTE: ALL RAILING REQUIRE PERIODIC MAINTENANCE ESPECIALLY THOSE SUBJECT TO OCEAN SALT AIR OR HARMFUL CHEMICAL ENVIRONMENTS (WITHIN 1/2 MILE) WHICH REQUIRE WASHING AT LEAST ONCE EVERY (6) MONTH. APPLICATION OF AN APPROVED UV PROTECTANT AFTER WASHING IS RECOMMENDED.
16. BOTTOM POST CONNECTION'S SELF DRILLING SCREWS TO BE FULLY PERPENDICULAR TO POST TO AVOID PERFORATION OF ANCHOR'S CHANNEL.

NOTE

**ALL CONFIGURATIONS ARE ALSO ALLOWED W/ CORE DRILL CONNECTION. SEE B/S-5 FOR SPECS.
 **GOOSE-NECK HANDRAIL OPTIONAL SEE SHEET 6 FOR SPECS.

ALLOWABLE LOADS

CONCENTRATED LOAD = 200 # (APPLIED IN ANY DIRECTION AT ANY POINT ALONG THE TOP)
 LINEAR LOAD = 50 lb/ft (APPLIED IN ANY DIRECTION AT ANY POINT ALONG THE TOP RAIL)
 WIND LOAD= 100 psf (FOR WIND LOADING)
 UNIFORM LOAD = 25 psf (FOR INTERMEDIATE RAILS, OVER THE GROSS AREA)

PRODUCT REVISED
 as complying with the Florida Building Code
 Acceptance No 21-1209.03
 Expiration Date 10/26/2027
 By *Heidi A. Martin*
 Miami Date Product Control

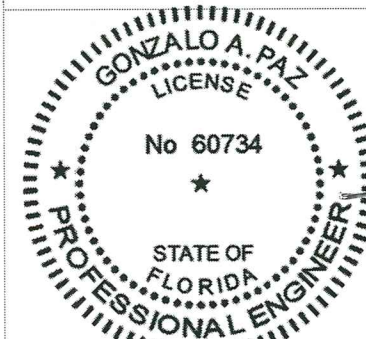

06/08/2022



EASTERN ENGINEERING GROUP
 3401 NW 82 AVE SUITE 370 Miami, Florida 33122
 Tel: (305) 599-8133 Fax: (305) 599-8076
 www.easterneg.com
 RAISSA R. LOPEZ, PE (Lic No-59399)
 GONZALO A. PAZ, PE (Lic No-60734)
 CERT. OF AUTHORIZATION No. 26655

REVISIONS	DESCRIPTION
No.	DATE

JOB No. 14 445
 DESIGNED & DRAWN:
 SCALE : AS SHOWN

ALUMINUM PICKET RAILING R04-4-21-2022
 V01
 3480 NW 21 Street
 Miami, Florida 33142
 Phone: (786) 256-4564
 WWW.LAYSESYSTEMS.COM
 Layze Systems™

5/27/2022

SHEET:
 S-1 OF 8

CLASSICAL BALCONY

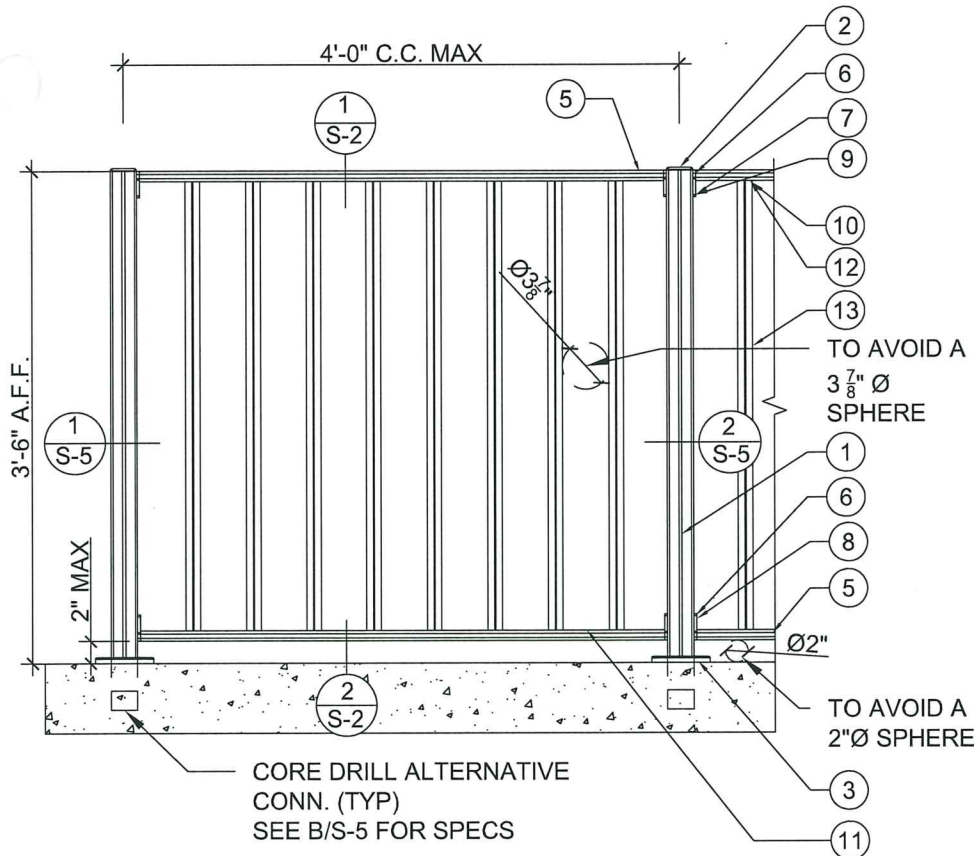

BALCONY W/ TOP RAIL

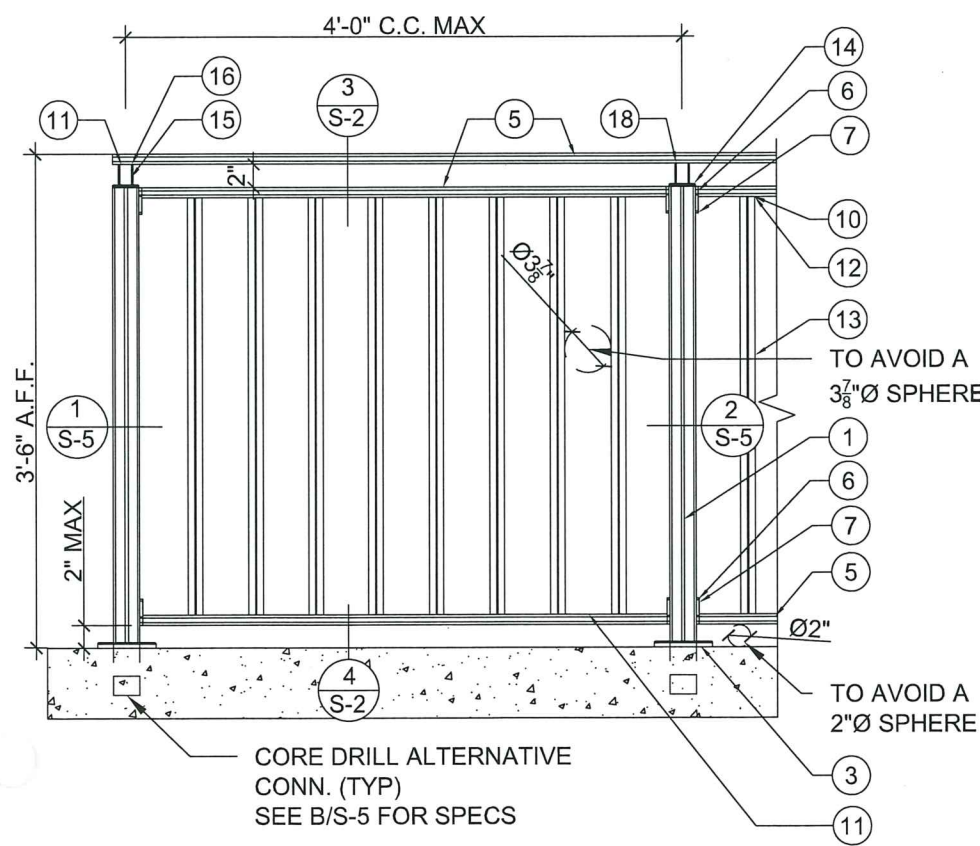

1 DETAIL
S-2 SCALE: 3"=1'-0"

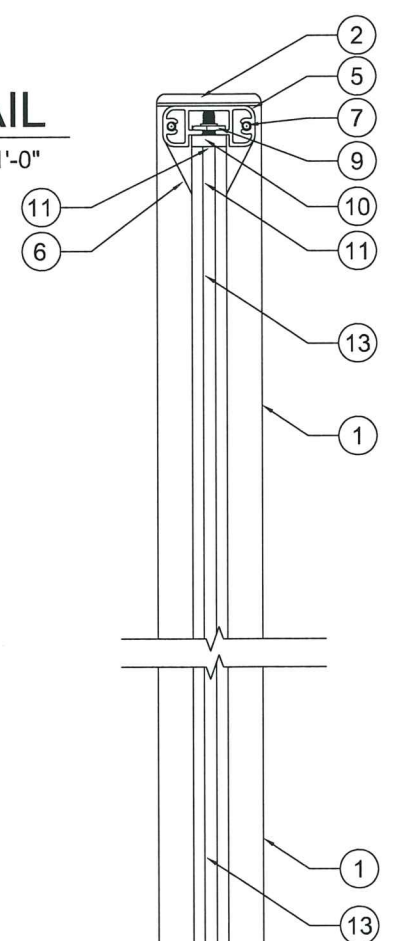

3 DETAIL
S-2 SCALE: 3"=1'-0"

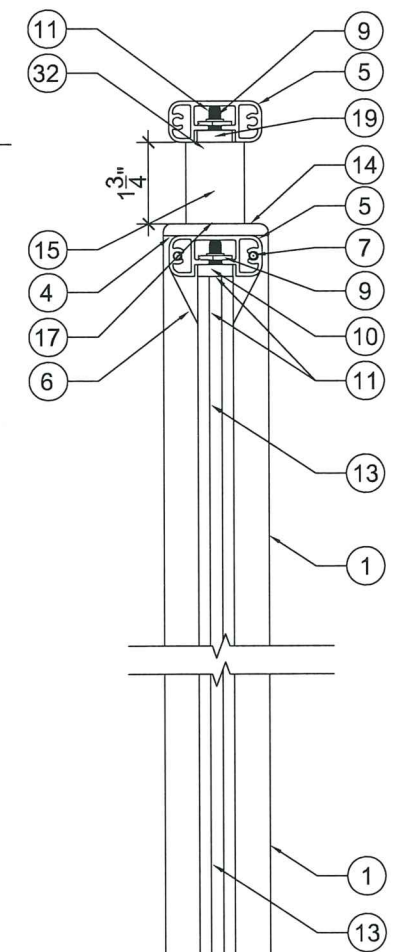

2 DETAIL
S-2 SCALE: 3"=1'-0"

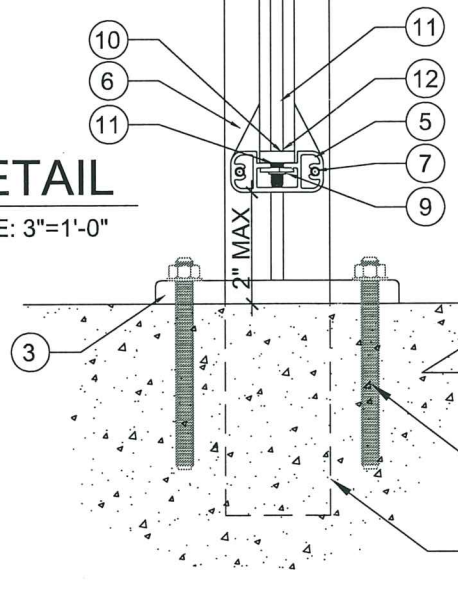

4 DETAIL
S-2 SCALE: 3"=1'-0"

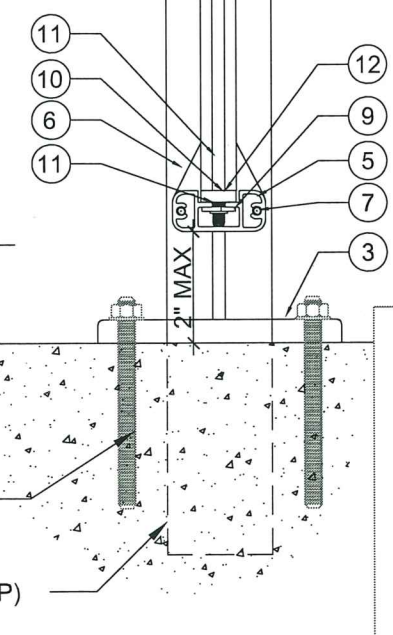

FINISHED FLOOR
BASE PLATE CONNECTION (TYP)
SEE A/S-5 FOR SPECS
CORE DRILL ALTERNATIVE CONN. (TYP)
SEE B/S-5 FOR SPECS

PRODUCT REVISED
as complying with the Florida
Building Code
Acceptance No 21-1209.03
Expiration Date 10/26/2027
By *Heidi A. Nelson*
Miami Data Product Control

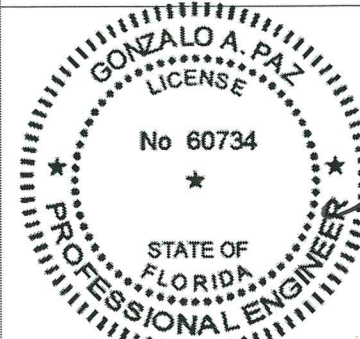

EASTERN ENGINEERING GROUP
3401 NW 82 AVE SUITE 370 Miami, Florida 33112
Tel: (305) 599-8133 Fax: (305) 599-9076
www.eeasterneng.com

RAISSA R. LOPEZ, PE (Lic No-59399)
 GONZALO A. PAZ, PE (Lic No-60734)
CERT. OF AUTHORIZATION No. 26655

REVISIONS	
No.	DESCRIPTION

JOB No. 14 445
DESIGNED & DRAWN: [Signature]
SCALE: AS SHOWN

ALUMINUM PICKET RAILING R04-4-21-2022
V01
3480 NW 21 Street
Miami, Florida 33142
Phone: (786) 256-4564
WWW.LAYSESYSTEMS.COM
Layze Systems™

5/27/2022

SHEET:
S-2 OF 8

06/08/2022

BALCONY W/ DOUBLE CHANNEL

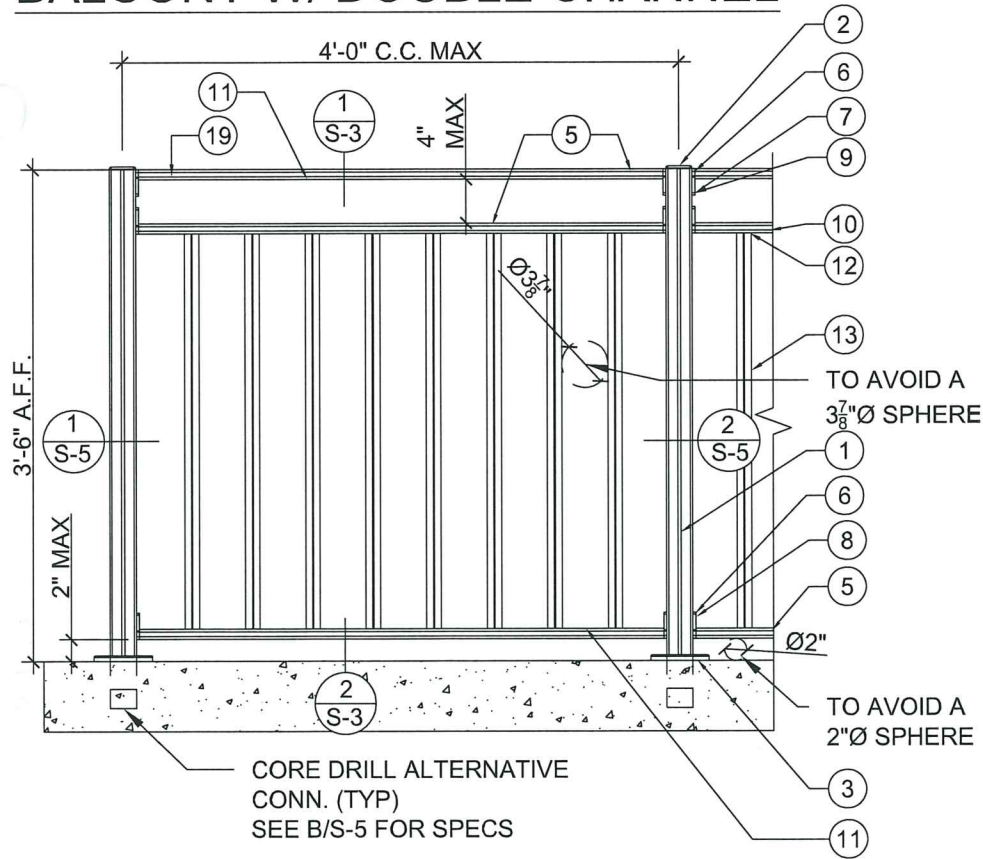

1 DETAIL
S-3 SCALE: 3"=1'-0"

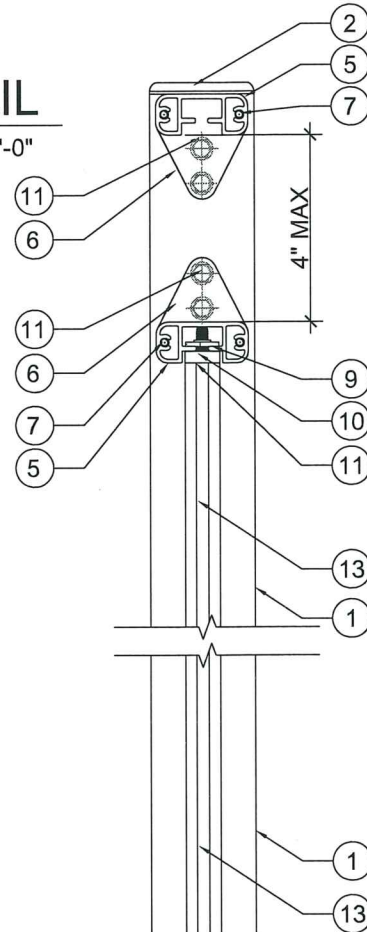

3 DETAIL
S-3 SCALE: 3"=1'-0"

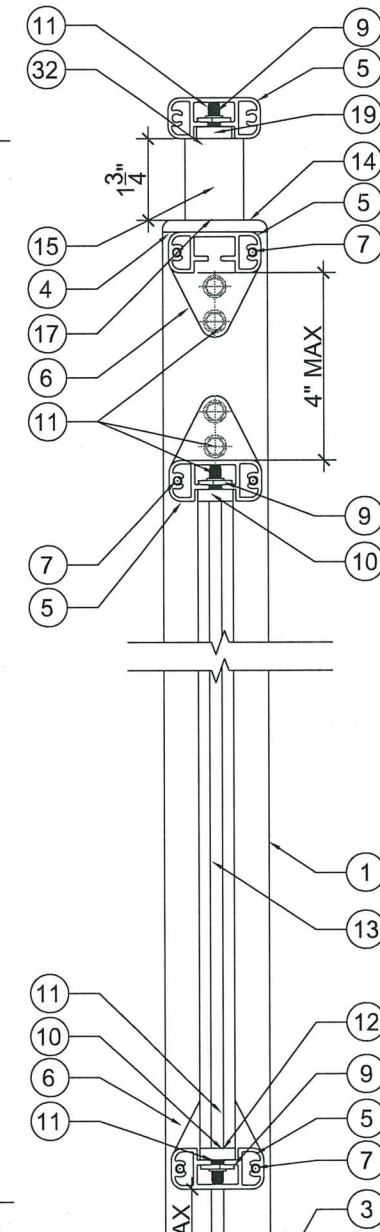

BALCONY W/ 2 CHANNELS & TOP RAIL

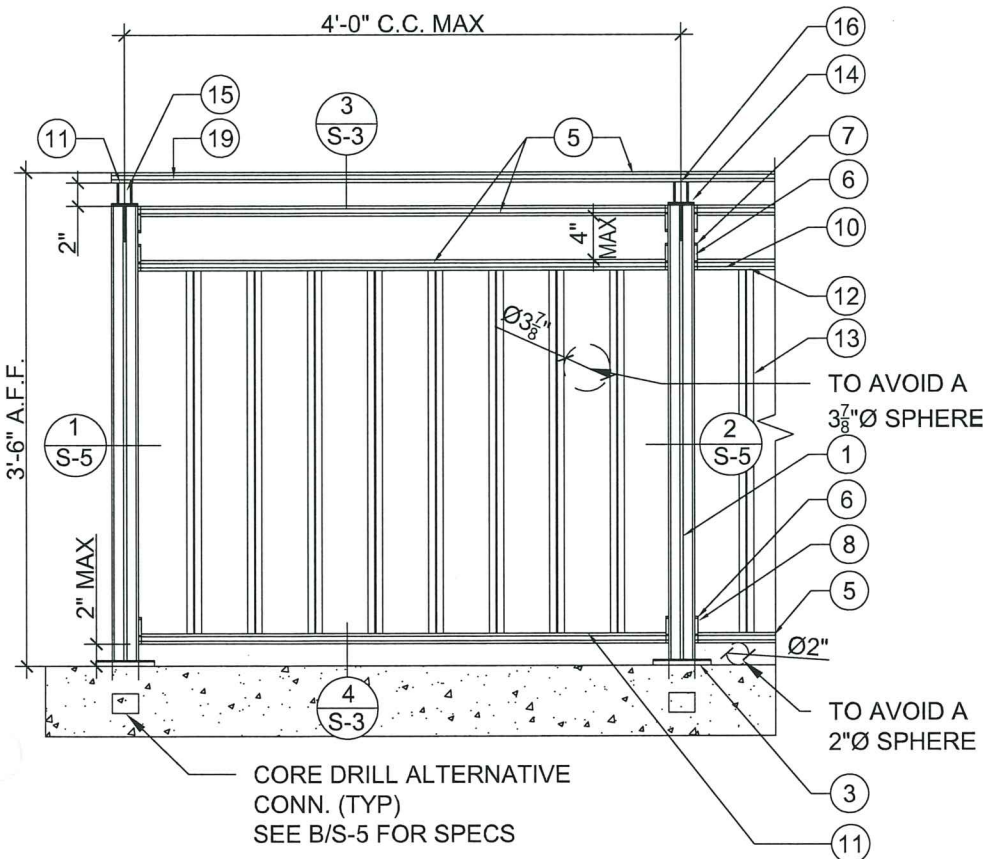

2 DETAIL
S-3 SCALE: 3"=1'-0"

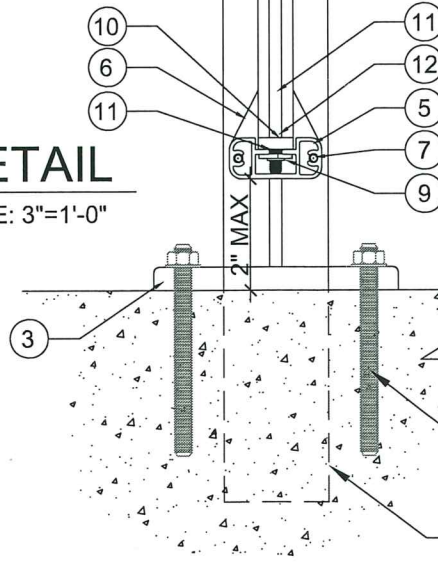

4 DETAIL
S-3 SCALE: 3"=1'-0"

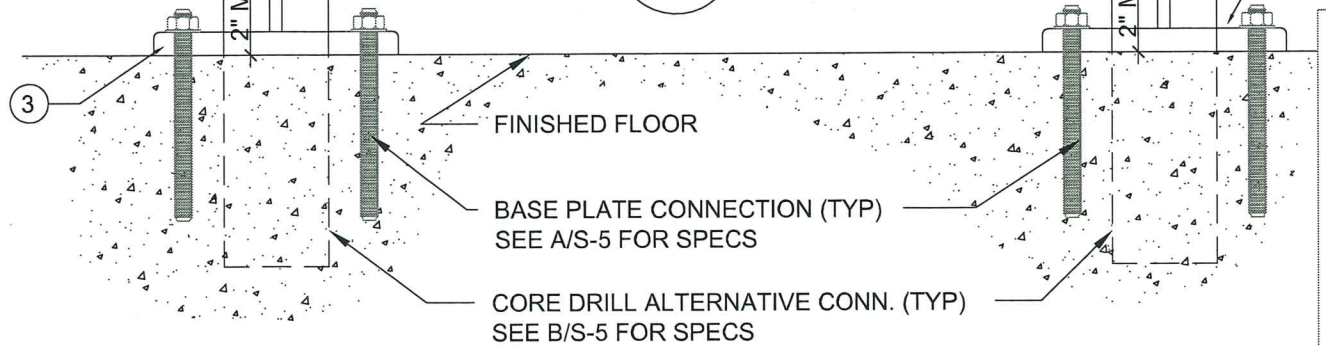

PRODUCT REVISED
as complying with the Florida
Building Code
Acceptance No 21-1209-03
Expiration Date 10/26/2027
By *Hely A. Mohr*
Miami Dade Product Control

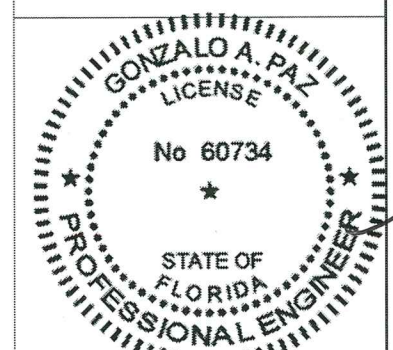

EASTERN ENGINEERING GROUP
3401 NW 82 AVE SUITE 370 Miami, Florida 33122
Tel: (305) 599-8133 Fax: (305) 599-8076
www.eeasterneg.com
RAISSA R. LOPEZ, PE (Lic No-59399)
GONZALO A. PAZ, PE (Lic No-60734)
CERT. OF AUTHORIZATION No. 26655

No.	DATE	DESCRIPTION

JOB No. 14 445
DESIGNED & DRAWN:
SCALE: AS SHOWN

ALUMINUM PICKET RAILING R04 4-21-2022
V01
3480 NW 21 Street
Miami, Florida 33142
Phone: (786) 256-4564
WWW.LAYZESYSTEMS.COM
Layze Systems™

5/27/2022



EASTERN ENGINEERING GROUP
 3401 NW 82 AVE SUITE 370 Miami, Florida 33142
 Tel: (305) 599-8133 Fax: (305) 599-9076
 www.easterneg.com

RAISSA R. LOPEZ, PE (Lic No-59399)
 GONZALO A. PAZ, PE (Lic No-60734)
 CERT. OF AUTHORIZATION No. 26655

REVISIONS	DESCRIPTION
No.	DATE

JOB No. 14 445
 DESIGNED & DRAWN:
 SCALE: AS SHOWN

ALUMINUM PICKET RAILING R04-4-21-2022
 V01
 3480 NW 21 Street
 Miami, Florida 33142
 Phone: (786) 256-4564
 WWW.LAYSESYSTEMS.COM
 Layze Systems™

5/27/2022

SHEET:
 S-4 OF 8

CLASSICAL STAIR

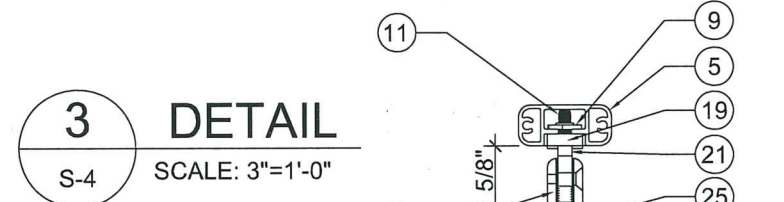
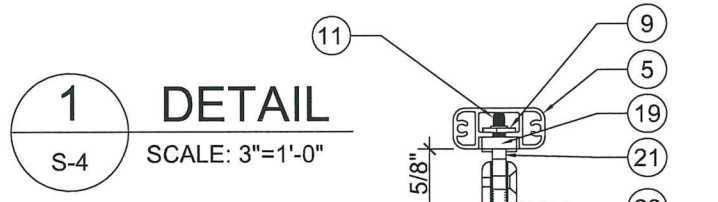
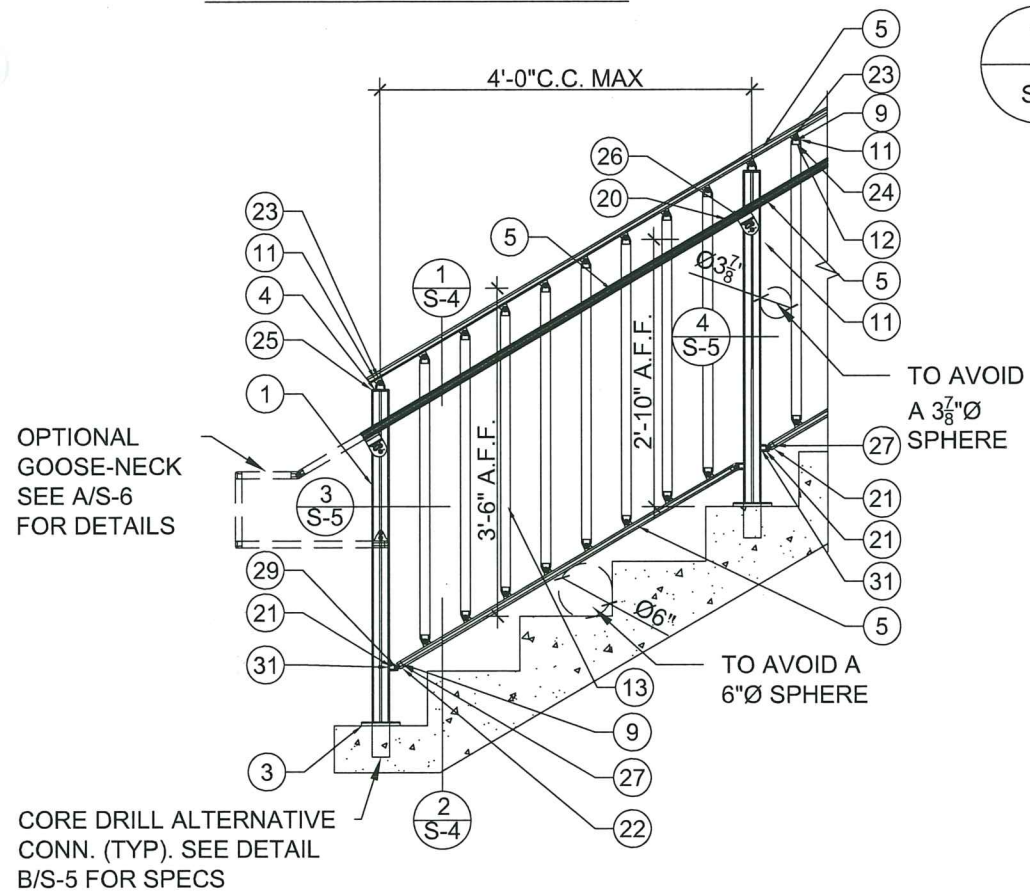

STAIR W/ TOP RAIL

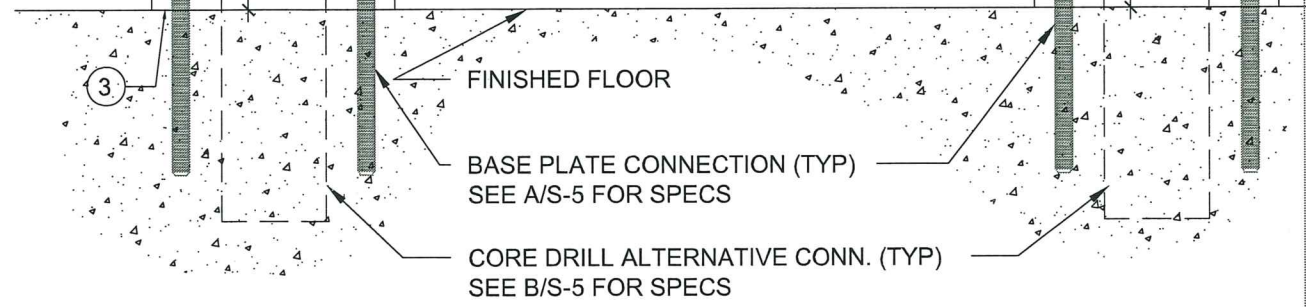
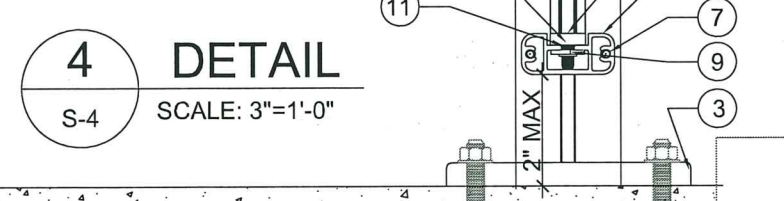
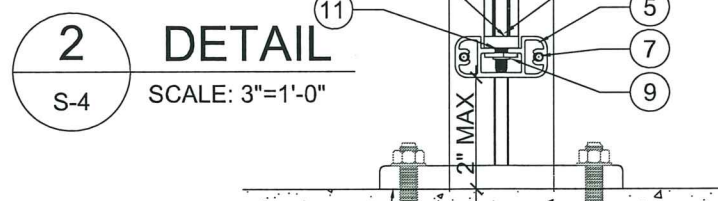
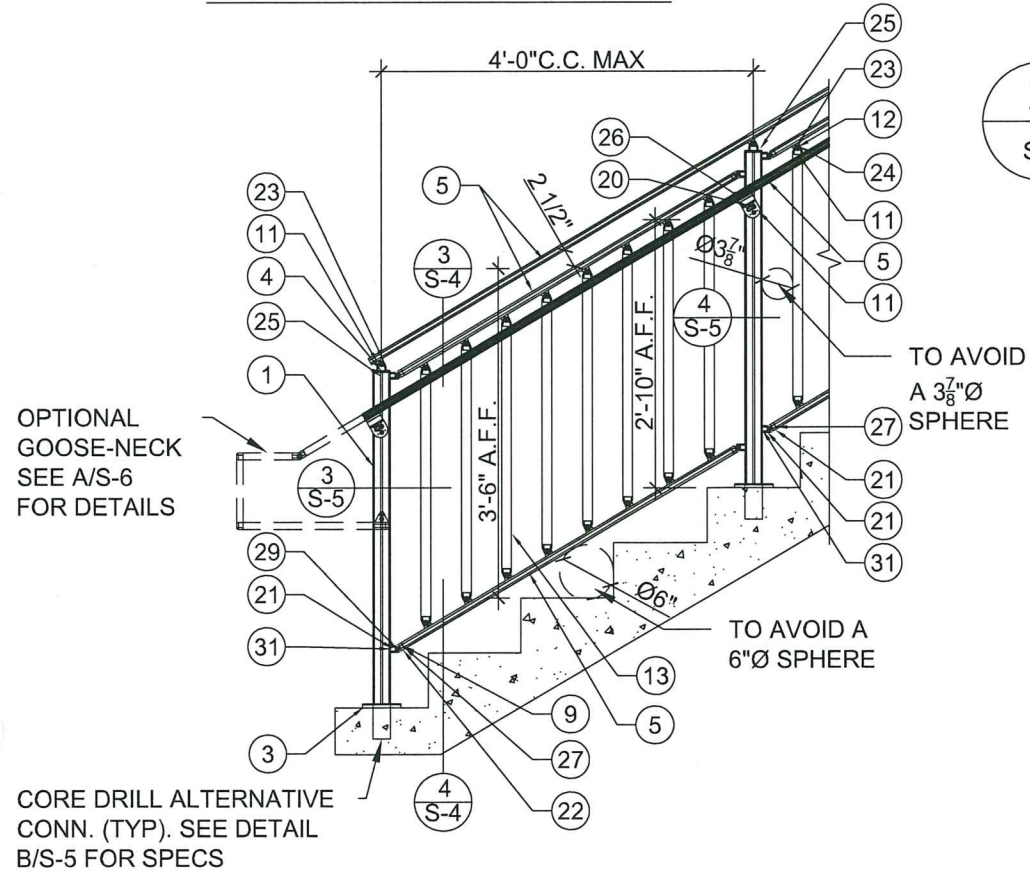

PRODUCT REVISED
 as complying with the Florida
 Building Code
 Acceptance No 21-1209.03
 Expiration Date 10/26/2027
 By *Hedy A. Malin*
 Miami Date Product Control

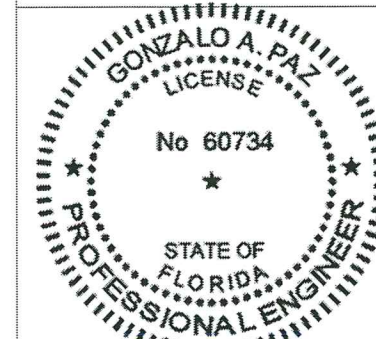

06/08/2022

CONNECTION NOTE:
FOR CORE DRILL ALTERNATIVE CONNECTION
DETAILS SEE B/S-5

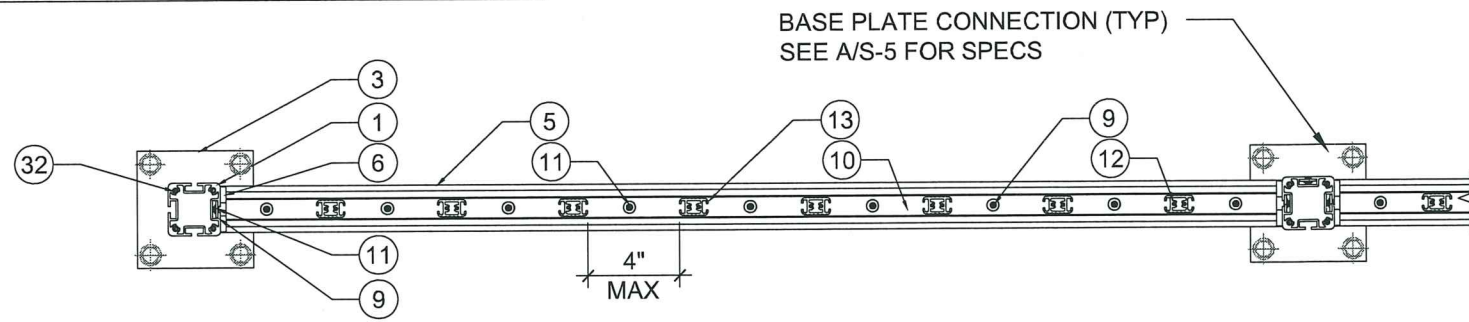

BASE PLATE CONNECTION (TYP)
SEE A/S-5 FOR SPECS

1 DETAIL
S-5 SCALE: 1 1/2"=1'-0"

2 DETAIL
S-5 SCALE: 1 1/2"=1'-0"

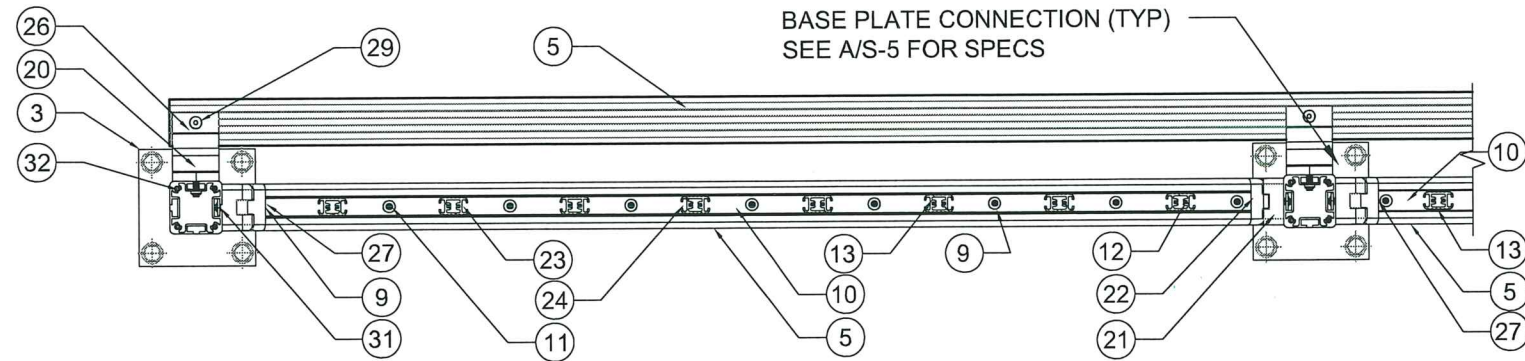

BASE PLATE CONNECTION (TYP)
SEE A/S-5 FOR SPECS

3 DETAIL
S-5 SCALE: 1 1/2"=1'-0"

4 DETAIL
S-5 SCALE: 1 1/2"=1'-0"

3 1/2" Ø CORE DRILL
W/ 5" EMBED INTO
10KSI NON-SHRINK
GROUT. 5" MIN EDGE
DISTANCE. 6" THICK
MIN 3KSI CONCRETE
SLAB (BY OTHERS)

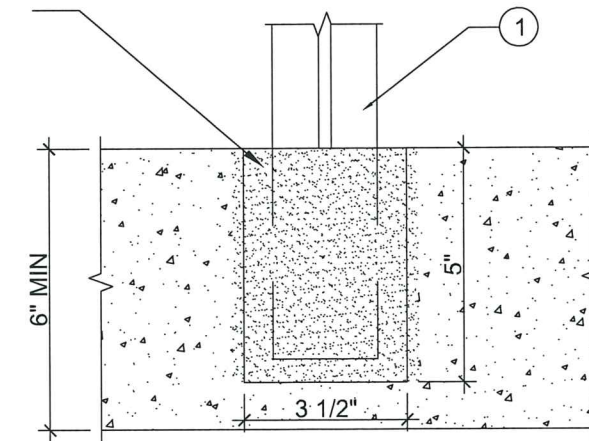

B CORE DRILL DETAIL
S-5 SCALE: 3"=1'-0"

(4) 3/8" Ø THREADED ROD
W/ G5 ADHESIVE BY
READ HEAD @ 4" OC
W/ 3 1/2" EMBED & MIN.
EDGE DIST.

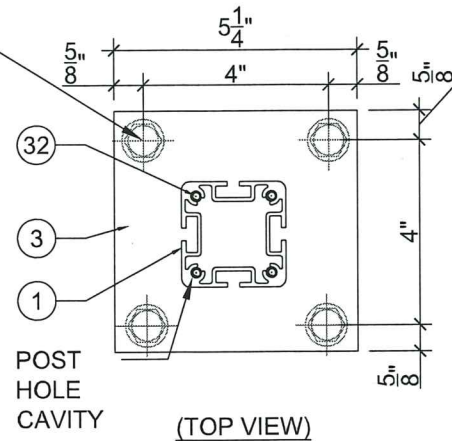

POST
HOLE
CAVITY

(TOP VIEW)

A BASE PLATE DETAIL
S-5 SCALE: 3"=1'-0"

(4) 3/8" Ø THREADED ROD
W/ G5 ADHESIVE BY
READ HEAD @ 4" OC
W/ 3 1/2" EMBED & MIN.
EDGE DIST.

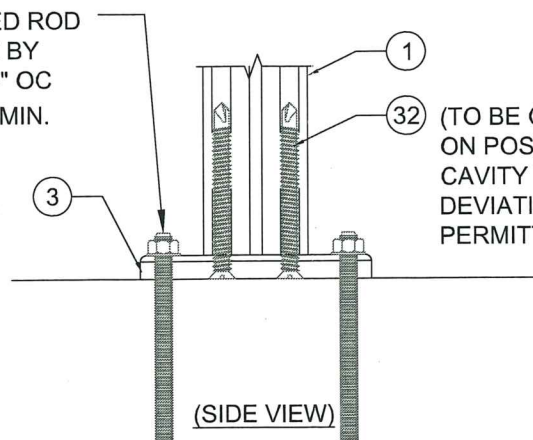

(TO BE CENTERED
ON POST HOLE
CAVITY WITH NO
DEVIATION
PERMITTED)

(SIDE VIEW)

C BASE PLATE DETAIL
S-5 SCALE: 3"=1'-0"

PRODUCT REVISED
as complying with the Florida
Building Code
Acceptance No 21-1209.03
Expiration Date 10/26/2027
By *Healy A. Maher*
Miami Design Product Control

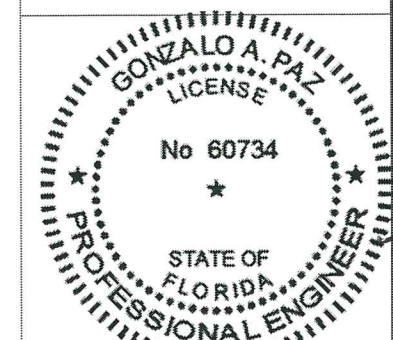

EASTERN ENGINEERING GROUP
3401 NW 82 AVE SUITE 370 Miami, Florida 33172
Tel: (305) 599-8733 Fax: (305) 599-8076
www.easterneg.com
RAISSA R. LOPEZ, PE (Lic No-59399)
GONZALO A. PAZ, PE (Lic No-60734)
CERT. OF AUTHORIZATION No. 26655

REVISIONS	DESCRIPTION
No.	DATE

JOB No. 14 445
DESIGNED & DRAWN:
SCALE: AS SHOWN

ALUMINUM PICKET RAILING R04-4-21-2022
V01
3480 NW 21 Street
Miami, Florida 33142
Phone: (786) 256-4564
WWW.LAYSYSTEMS.COM
Layze Systems™

5/27/2022

SHEET:
S-5 OF 8

06/08/2022

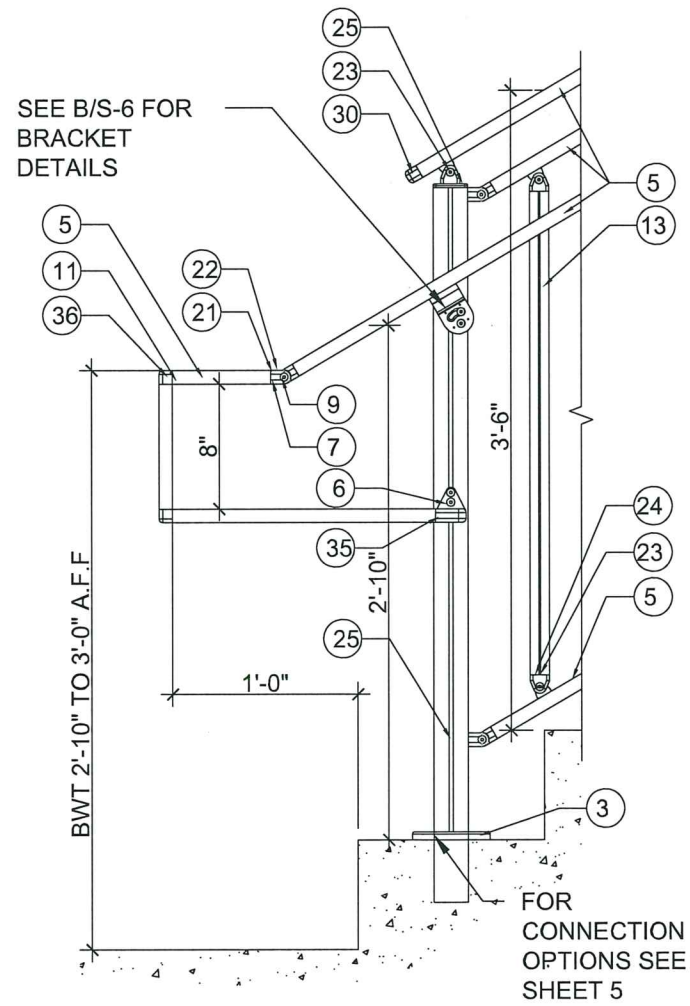

A HANDRAIL DETAIL
S-6 SCALE: 1"=1'-0"

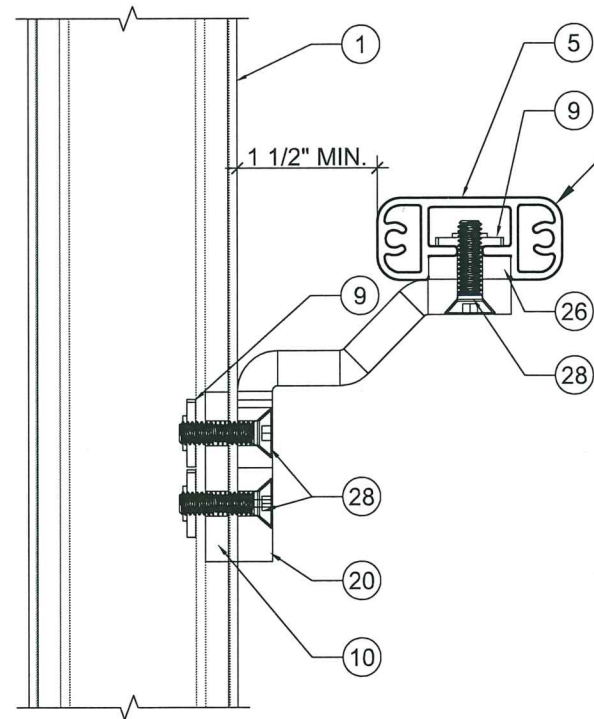

B BRACKET DETAIL
S-6 SCALE: 6"=1'-0"

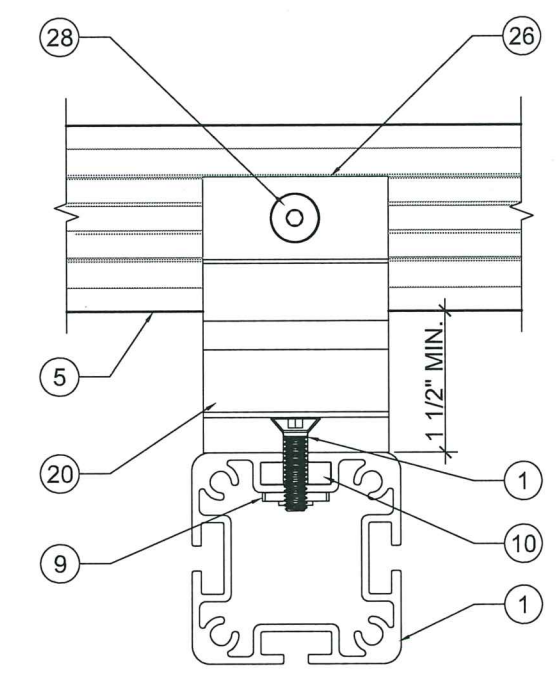

PRODUCT REVISED
as complying with the Florida
Building Code
Acceptance No. 21-1209.03
Expiration Date 10/26/2027
By *Heidi A. Paz*
Miami Data Product Control

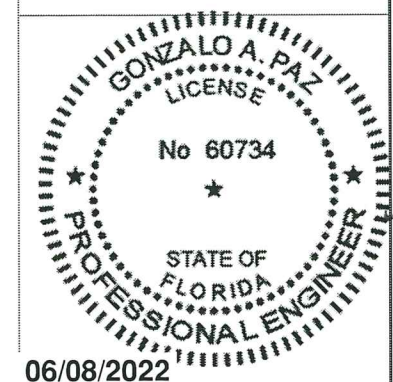

EASTERN ENGINEERING GROUP
3401 NW 82 AVE SUITE 370 Miami, Florida 33122
Tel. (305) 599-8733 Fax. (305) 599-8076
www.eesterneg.com
RAISSA R. LOPEZ, PE (Lic No-58399)
GONZALO A. PAZ, PE (Lic No-60734)
CERT. OF AUTHORIZATION No. 26655

No.	DATE	REVISIONS DESCRIPTION

JOB No. 14 445
DESIGNED & DRAWN:
SCALE: AS SHOWN

ALUMINUM PICKET RAILING R04-4-21-2022
V01
3480 NW 21 Street
Miami, Florida 33142
Phone: (786) 256-4564
WWW.LAYSESYSTEMS.COM
Layze Systems™

5/27/2022

SHEET:
S-6 OF 8



EASTERN ENGINEERING GROUP
 3401 NW 82 AVE SUITE 370 Miami, Florida 33122
 Tel: (305) 599-8733 Fax: (305) 599-8076
 www.easterneeg.com

RAISSA R. LOPEZ, PE (Lic No-59399)
 GONZALO A. PAZ, PE (Lic No-60734)
CERT. OF AUTHORIZATION No. 26655

No.	DATE	REVISIONS DESCRIPTION

JOB No. 14 445
 DESIGNED & DRAWN:
 SCALE: AS SHOWN

ALUMINUM PICKET RAILING R04-4-21-2022
 V01
 3480 NW 21 Street
 Miami, Florida 33142
 Phone: (786) 256-4564
 WWW.LAYSESYSTEMS.COM
 Layze Systems™

5/27/2022

SHEET:
 S-7 OF 8

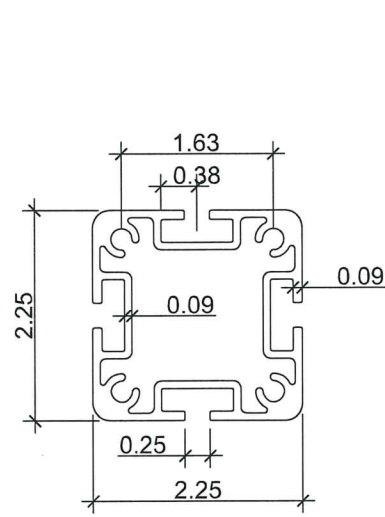

(1) POST

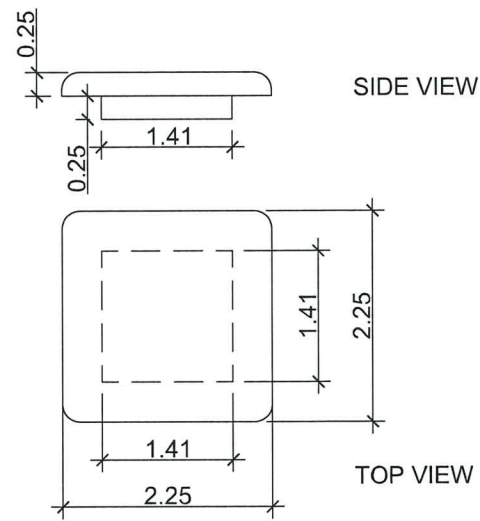

(2) TOP CAP (FLAT)

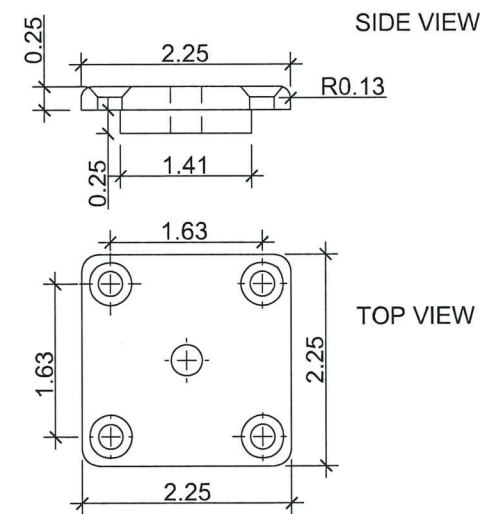

(14) TOP CAP-TOP RAIL

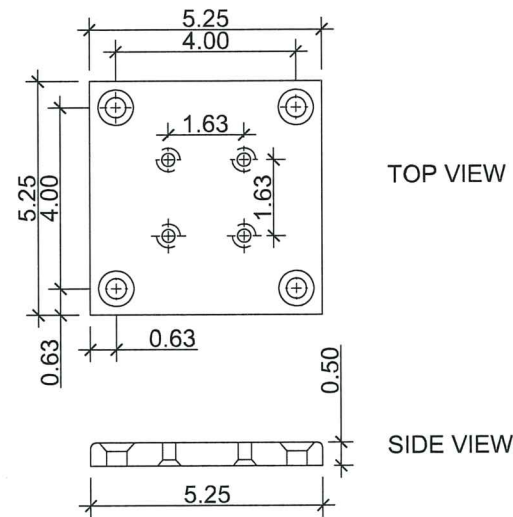

(3) BASE PLATE

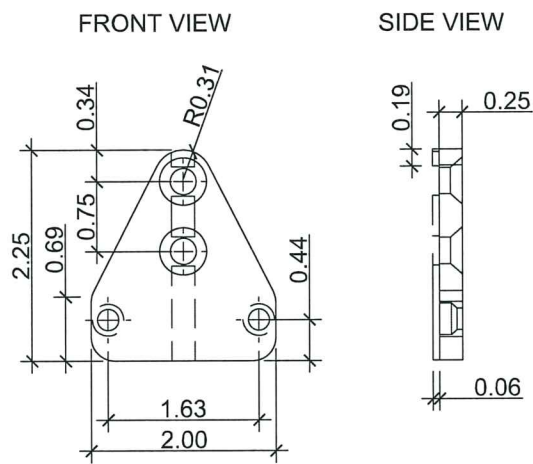

(6) CHANNEL END PLATE

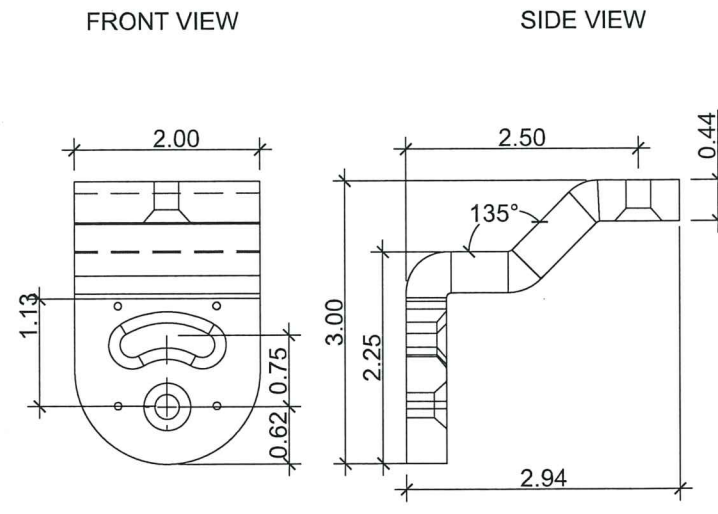

(20) GRAB RAIL BRACKET

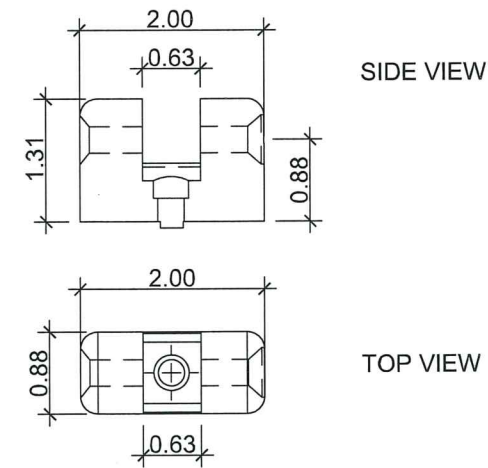

(22) FEMALE CHANNEL CONNECTOR

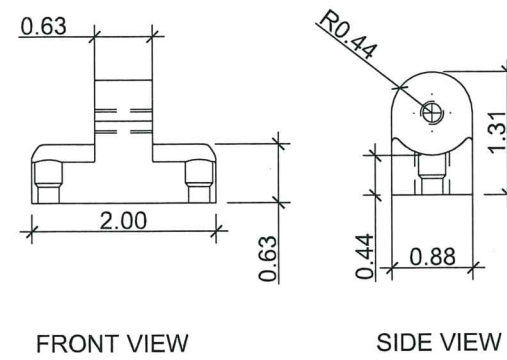

(21) MALE CHANNEL CONNECTOR

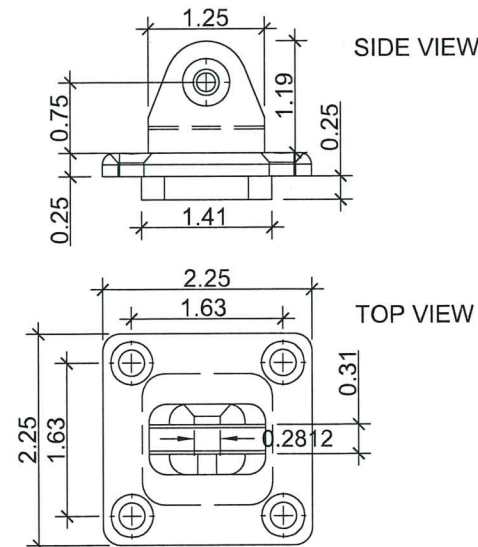

(25) TOP CAP-STAIRS

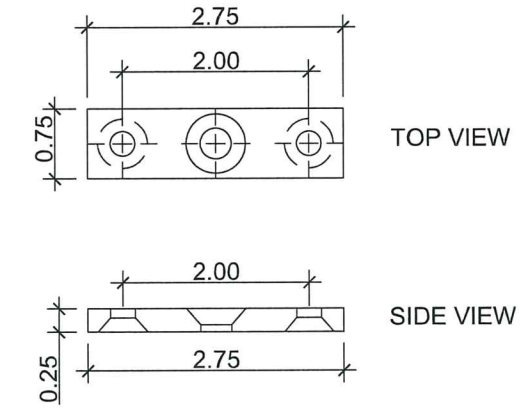

(16) TOP RAIL CONNECTOR PLATE

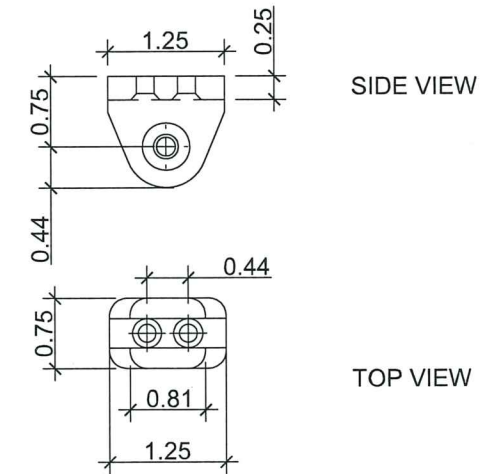

(24) FEMALE PICKET CONNECTOR

PRODUCT REVISED
 as complying with the Florida
 Building Code
 Acceptance No. 21-12-09.03
 Expiration Date 10/26/2027
 By: *Healy A. Miller*
 Miami Date Product Control

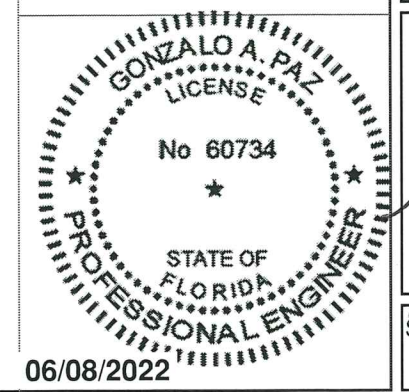

ITEM No.	PART No.	DESCRIPTION	MATERIAL
EXTRUSIONS & COMPONENTS			
1	E-1013	POST	6005-T5
2	C-1024	TOP CAP (FLAT)	6061-T6
3	C-1021	BASE PLATE	6061-T6
5	E-1014	CHANNEL	6005-T5
6	C-1022	CHANNEL END PLATE	6061-T6
10	C-1020	SCREW PLATE (CLASSICAL)	6061-T6
13	E-1015	PICKET	6005-T5
14	C-1025	TOP CAP (TOP RAIL)	6061-T6
15	C-1023	TOP RAIL POST BLOCK	6061-T6
16	C-1034	TOP RAIL CONNECTOR PLATE	---
19	C-1048	SCREW PLATE (TOP CHANNEL)	---
20	C-1031	GRAB RAIL BRACKET	6061-T6
21	C-1030	MALE CHANNEL CONNECTOR	6061-T6
22	C-1029	FEMALE CHANNEL CONNECTOR	6061-T6
23	C-1027	MALE CONNECTOR	6061-T6
24	C-1028	FEMALE PICKET CONNECTOR	6061-T6
25	C-1026	TOP CAP STAIR	6061-T6
26	C-1066	GRAB RAIL BRACKET SPACER PLATE	6061-T6
35	C-1077	90° CHANNEL CONNECTOR	6061-T6
36	C-1076	CHANNEL CORNER CONNECTOR	6061-T6
HARDWARE			
4	H079-FH	#14X3" LG. FH SQ.DRIVE 18-8	SS
7	H053 (MH)	#12X 1/2" LG. FH SQ.DRIVE 18-8	SS
8	H538-FH	1/4-20X1/2" LG. FLATHEAD SOCKET CAP SCREW 18-8	SS
9	H139	T-NUT 1/4-20	SS
11	H540-FH	1/4-20X 3/4" LG. FLATHEAD SOCKET CAP SCREW 18-8	SS
12	H019-FH	#8x1.25" LG. FH SQ.DRIVE 18-8	SS
17	H030	5/16-18 HEX LOCK NUT	SS
18	H595-FH	5/16-18X3"LG SOCKET CAP SCREW 18-8	SS
27	H539-BH	1/4-20 x5/8" BH SOCKET CAP SCREW 18-8	SS
28	H542-FH	1/4-20 x1" FH SOCKET CAP SCREW 18-8	SS
29	H541-FH	1/4-20 x7/8" FH SOCKET CAP SCREW 18-8	SS
30	PP-1002	PLASTIC COVER PLATE	PL
31	H059	#12X 1/2" LG. FH SQ.DRIVE 18-8	SS
32	H599-FH	5/16-18X3.5"LG FH SOCKET CAP SCREW 18-8	SS

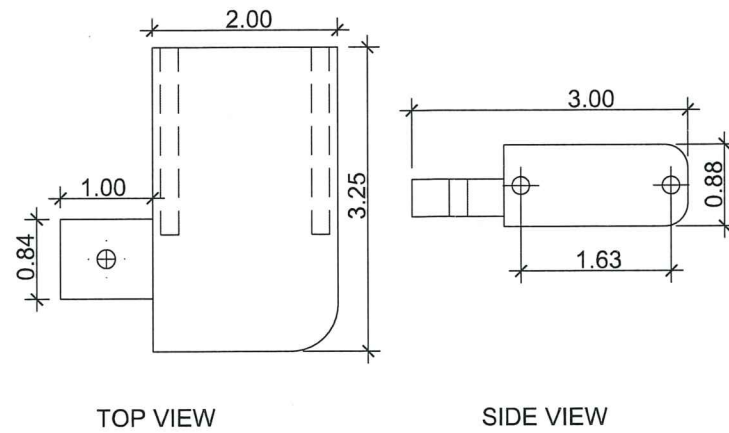

(35) CHANNEL 90° CONNECTOR

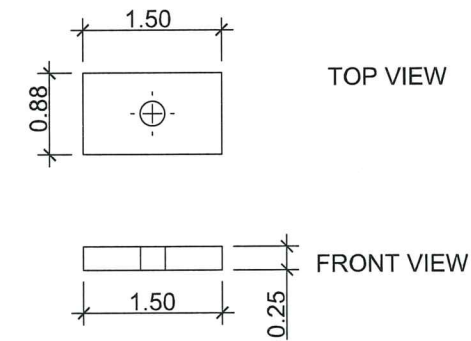

(26) GRAB RAIL BRACKET SPACER

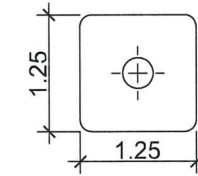

(15) TOP RAIL POST BLOCK

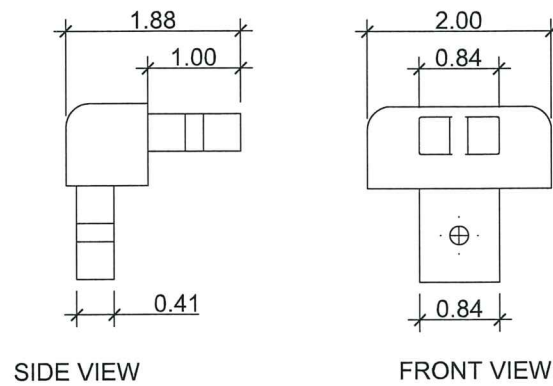

(36) CHANNEL CORNER CONNECTOR

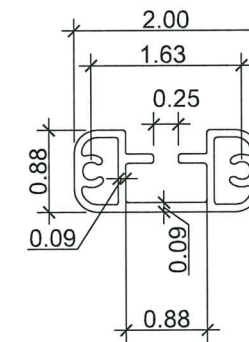

(5) CHANNEL

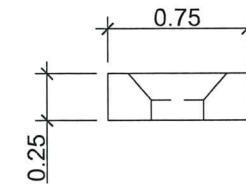

(10), (19) SCREW PLATE

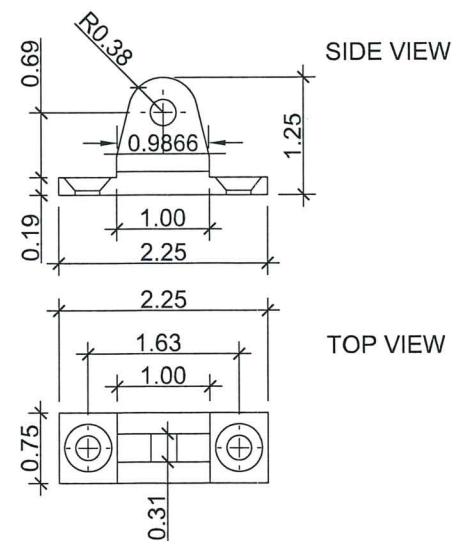

(23) MALE CONNECTOR

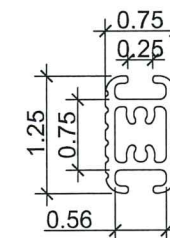

(13) PICKET



EASTERN ENGINEERING GROUP
 3401 NW 82 AVE SUITE 370 Miami, Florida 33122
 Tel: (305) 599-8133 Fax: (305) 599-8076
 www.easterneg.com
 RAISSA R. LOPEZ, PE (Lic No-59399)
 GONZALO A. PAZ, PE (Lic No-60734)
 CERT. OF AUTHORIZATION No. 26655

REVISIONS	DESCRIPTION	DATE	No.

JOB No. 14 445
 DESIGNED & DRAWN:
 SCALE: AS SHOWN

ALUMINUM PICKET RAILING R04 -4-21-2022
 V01
 3480 NW 21 Street
 Miami, Florida 33142
 Phone: (786) 256-4564
 WWW.LAYSESYSTEMS.COM
 Layze Systems™

PRODUCT REVISED
 as complying with the Florida
 Building Code
 Acceptance No 21-1209.03
 Expiration Date 10/26/2027
 By Hedy A. Melon
 Miami Data Product Control

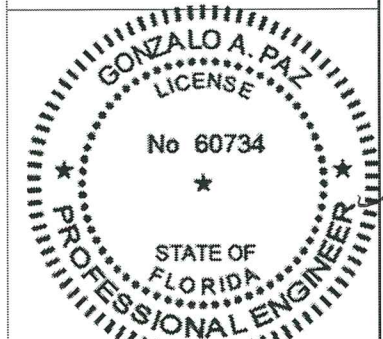

5/27/2022

06/08/2022

SHEET:
 S-8 OF 8